

cod. FORGUSTO-PE/-ZU

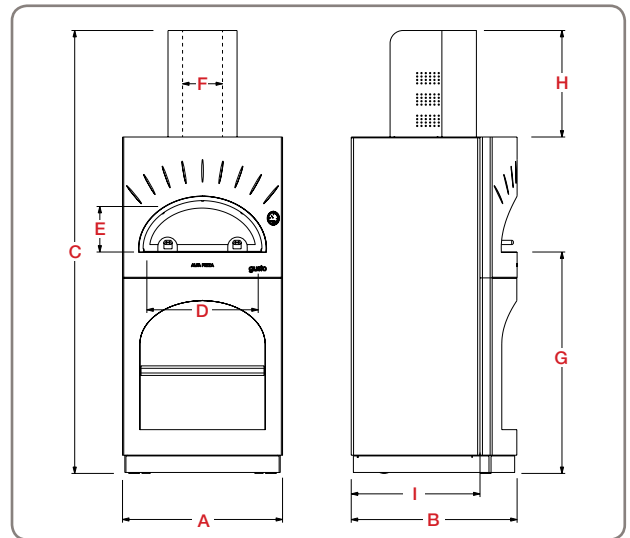

MISURE / DIMENSIONS



MISURE / DIMENSIONS

<b>A</b>	Larghezza totale / Total width	74 Cm / 29 In
<b>B</b>	Lunghezza totale / Total length	77 Cm / 30,3 In
<b>C</b>	Altezza totale / Total height	208 Cm / 81,9 In
<b>D</b>	Larghezza bocca / Oven mouth width	51 Cm / 20 In
<b>E</b>	Altezza bocca / Oven mouth height	21,5 Cm / 8,4 In
<b>F</b>	Diametro cappa / Chimney diameter	18 Cm / 7 In
<b>G</b>	Altezza piano cottura / Oven floor height	104 Cm / 40,9 In
<b>H</b>	Altezza copricanna fumaria / Flue panel covering height	50 Cm / 19,7 In
<b>I</b>	Profondità d'incasso / Recessed oven depth	59,6 Cm / 23,4 In

CARATTERISTICHE TECNICHE / TECHNICAL DETAILS

Peso / Weight	165 Kg / 363 Lbs		
Area piano forno / Oven floor area	Dim. piano forno / Oven floor dim.	0,3 m <sup>2</sup> / 3,2 In <sup>2</sup>	60x50 cm / 23,6x19,6 In
Minuti per scaldare / Heating time	15		
N° pizze alla volta / Pizza capacity	2		
Infornata di pane / Bread capacity	2 Kg / 4,4 Lbs		
Consumo medio / Average fuel consumption	3 Kg/h / 6,6 Lbs/h		
Temperatura massima / Max oven temperature	400 °C 752 °F		
Combustibile consigliato / Recommended fuel	Ciocchi diam. max. 5 Cm, potature / Max. 1,9 In diam. logs, trimmings		

MONTAGGIO e componenti / ASSEMBLY and parts list

	Cod.	N°	Desc.
<b>a</b>	YCMGU	1	Camera forno
<b>b</b>	XPRGU	1	Piano refrattario
<b>c</b>	XCSGU	1	Corpo struttura
<b>d</b>	XCCANGU	1	Copricanna
<b>e</b>	AFDGU	1	Archetto frontale
<b>f</b>	XMENGU	1	Ripiano
<b>g</b>	XBTTGU	1	Battiscopa
<b>h</b>	YT19063	1	Termometro
<b>i</b>	YSPOGU	1	Sportello inox/vetro
<b>l</b>	YR10040	2	Ruote

